

- cification in the staghorn coral *Acropora acuminata*: Variations in apparent skeletal incorporation of radioisotopes due to different methods of processing. *Mar. Biol.* **43**: 57–62.
- DODGE, R. E. 1978. The natural growth records of reef building corals. Ph.D. thesis, Yale Univ.
- DUSTAN, P. 1975. Growth and form in the reef-building coral *Montastrea annularis*. *Mar. Biol.* **33**: 101–107.
- GOREAU, T. F., AND N. I. GOREAU. 1959. The physiology of skeleton formation in corals. 2. Calcium deposition by hermatypic corals under various conditions in the reef. *Biol. Bull.* **118**: 416–427.
- HIGHSMITH, R. C. 1979. Coral growth rates and environmental control of density banding. *J. Exp. Mar. Biol. Ecol.* **37**: 105–125.
- ISDALE, P. 1977. Variation in growth rate of hermatypic corals in a uniform environment. *Proc. 3rd Int. Coral Reef Symp. (Univ. Miami)* **2**: 403–408.
- LEWIS, J. B., F. AXELSEN, I. GOODBODY, C. PAGE, AND G. CHISLETT. 1968. Comparative growth rates of some reef corals in the Caribbean. *McGill Univ., Mar. Sci. Ms. Rep.* 10, p. 1–27.
- SHINN, E. A. 1966. Coral growth rate, an environmental indicator. *J. Paleontol.* **40**: 233–240.
- TAYLOR, D. L. 1978. Nutrition of algal-invertebrate symbiosis. 2. Effects of exogenous nitrogen sources on growth, photosynthesis and the rate of excretion by algal symbionts in vivo and in vitro. *Proc. R. Soc. Lond. Ser. B* **201**: 401–412.

Submitted: 21 December 1979

Accepted: 22 May 1980

Limnol. Oceanogr., 25(6), 1980, 1117–1121
© 1980, by the American Society of Limnology and Oceanography, Inc.

Vertical distribution of invertebrate drift in a large river¹

Abstract—Invertebrate drift in large rivers has often been sampled at only one depth, under the assumption that drift density is equal throughout the water column. A new sampling apparatus showed that the vertical distribution of drift density for the baetid mayflies *Pseudocloeon* and *Baetis* and for the caddisflies *Hydropsyche* and *Cheumatopsyche* was not uniform.

Invertebrate drift, or downstream transport (Waters 1972), is a natural event in the lives of many members of the stream benthos. The study of invertebrate drift and its role in the production cycle of running water, however, has been limited for the most part to small streams because established sampling techniques are not suitable for depths over 0.5 m. Several workers have used floating nets or modified plankton samplers anchored to the substrate or suspended in midwater (Elliott 1967; Ulfstrand 1968). Pearson and Kramer (1969) developed a waterwheel-driven sampler and suggested it for large rivers. Each of these methods samples a single stratum

of water, and it is assumed that drift density—the number of organisms caught per unit volume of water sampled—is evenly distributed for all taxa throughout the water column. We have re-evaluated this hypothesis through the design and use of a new sampling apparatus which permits multilevel sampling in water exceeding 0.5 m.

Our work was done on the Mississippi River near Monticello, Wright County, Minnesota, from July 1973 through July 1974. At two sampling sites, at the end of short riffles where the substrate was primarily gravel and rubble and within 10–20 m of the bank, the apparatus was set at depths ranging from 0.44 to 1.29 m. The current velocity ranged from 0.2 to 1.5 m·s⁻¹ and the daily river discharge from 48 to 345 m³·s⁻¹ over the sampling periods.

Drift sampling nets, 15 × 15 × 145 cm, were made of 452-mesh Nitex (openings about 452 μm) secured to a brass-rod frame like that of Waters (1962) (Fig. 1A, B). Pieces of steel conduit, 15 cm long, were brazed to the sides of the brass frame to act as points of attachment to what we called a “net-stack frame” (Fig. 1C), made of 2.5-cm-square iron tubing.

¹ This research was supported by Northern States Power Company, Minneapolis, Minnesota 55401.

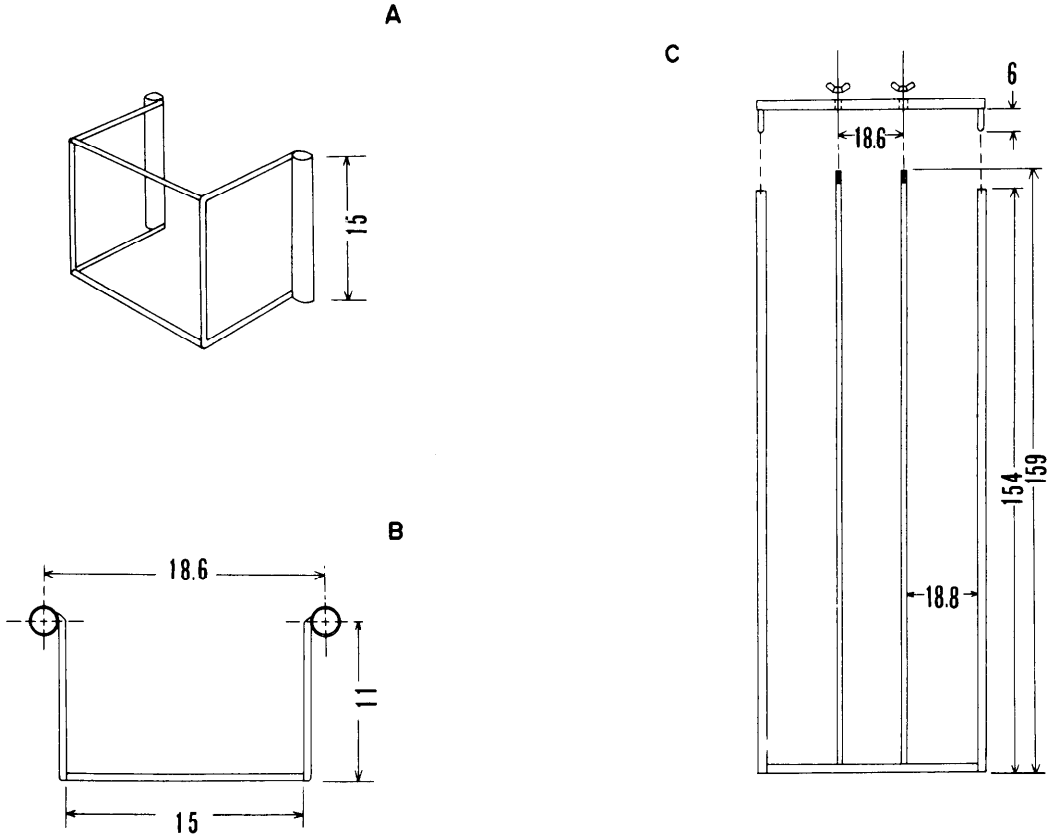

Fig. 1. A, B—Brass rod drift net frame with steel conduit attachment tubes; C—net-stack frame with center rods to receive conduit tubes of net frames. (Numbers = centimeters.)

Two 1.3-cm-diameter steel rods anchored to the base of the net-stack frame received the conduit tubes of the brass net frames which could then be placed in a vertical stack. Additional 15-cm lengths of conduit separated one net in a stack from another. The top of the net-stack frame was secured with wingnuts threaded onto the rods.

The net-stack frame with its stack of nets was held in the stream by a "river frame" (Fig. 2), also made of 2.5-cm-square iron tubing. Flat iron plates welded to the face of the frame form a channel into which the net-stack frame could be lowered and held in place facing into the river flow (Fig. 2).

The river frame was anchored to the river bottom with 180-cm lengths of iron reinforcing rod driven into the substrate

before each sampling period. A net-stack frame with its vertical stack of nets was lowered into the fixed river frame from an anchored boat and left in position. The number of nets used depended on the depth; the bottom net was always set just above the substrate and the top net at or just below the water surface. After 4 h the net-stack frame was removed from the river frame and replaced by a clean stack of nets. The sample nets could easily be removed from the net-stack frame to process the accumulated material. In this way the entire water column was sampled, and the organisms collected in the stack of nets represented the vertical distribution of drift.

Current velocity was measured at the mouth of each net with a Gurley model 625 pygmy current meter at the begin-

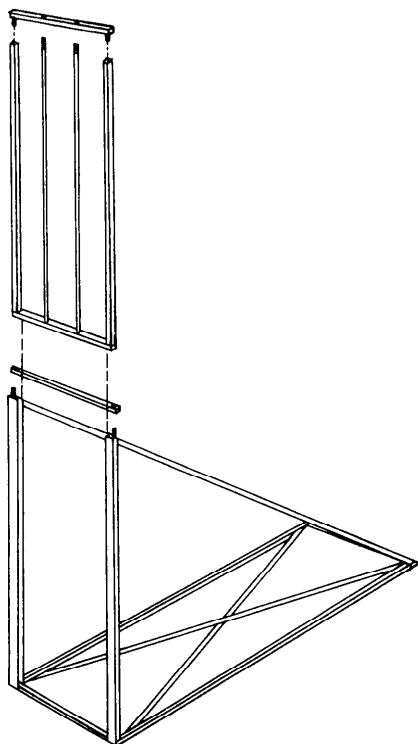

Fig. 2. Alignment of net-stack frame and channels at anterior face of fixed river frame.

ning and end of each sampling. During high flow, current velocity was measured with a Price AA current meter. The volume of water filtered by each net during a given period was calculated as the product of the average water velocity at the net mouth, the cross-sectional area of the net mouth, and the duration of sampling. At the end of each 24-h sampling period the entire apparatus was removed from the stream.

The material from each net was subsampled before sorting, identification, and counting. The total number of organisms in the original sample was estimated from these subsamples.

The mayflies *Pseudocloeon* and *Baetis* and the caddisflies *Hydropsyche* and *Cheumatopsyche* were predominant members of the benthos in the study area. The two closely related genera in each order were combined for this study.

If the drift density is equal throughout the water column, the number of organisms captured in a net should be directly proportional to the volume of water sampled by that net. In a vertical stack of nets the expected number of organisms in any one net should be equal to the total number of organisms in all of the nets times the proportion of the total volume of water sampled by the designated net. In this way the total number of organisms is distributed over the vertical stack of nets as though the density of organisms were equal throughout the water column. The calculated expected values can be compared with the observed number of organisms actually captured in each net by using the χ^2 goodness-of-fit test where

$$\chi^2 = \sum \frac{(\text{observed value} - \text{expected value})^2}{\text{expected value}}$$

Although the values used in the χ^2 statistic represent the number of organisms captured, the expected values have been calculated under the null hypothesis to reflect an even vertical distribution of drift density, so that a significant χ^2 value indicates an uneven vertical distribution of drift density.

This analysis was applied separately to the daytime and nighttime drift data for the *Pseudocloeon-Baetis* group and the *Hydropsyche-Cheumatopsyche* group, since both showed nocturnal peaks in abundance. Data from periods of low abundance of organisms were not used because the sample size was not large enough to provide sensitive tests of differences between strata. The test results are summarized in Tables 1 and 2. The position of the nets having the catch most deviant from the expected value, and thus making the greatest contribution to the χ^2 value, is also shown. The net having the catch with the largest positive deviation from the expected value will be referred to as showing the greatest overabundance, the net having the catch with the largest negative deviation as showing the greatest underabundance.

Thirteen of fifteen vertical distribution

Table 1. Results of χ^2 goodness-of-fit analyses for vertical distribution of daytime and nighttime drift for *Pseudocloeon-Baetis* group. NS—Lack of significant difference at 0.05 level. Position of nets having greatest under- and overabundance of organisms, based on expected value, is shown in the columns (T—top net; To—top net in a stack of two; M—middle net; Mu—upper middle net in a stack of four; Ml—lower middle net in a stack of four; B—bottom net, Bo—bottom net in a stack of two).

Period	Site 1			Site 2		
	Test result	Under	Over	Test result	Under	Over
Daytime drift						
1973						
27-28 Jul	*	B	M	*	B	M
13-14 Aug	*	B	T	*	B	Ml
28-29 Aug	*	T	B	*	T	B
11-12 Sep	NS			NS		
28-29 Sep	*	To	Bo	NS		
1974						
21-22 Jun	—	—	—	†	B	T
12-13 Jul	‡	T	B	*	M	B
23-24 Jul	*	B	T	*	B	T
Nighttime drift						
1973						
27-28 Jul	*	B	T	*	B	T
13-14 Aug	*	B	Mu	*	B	T
28-29 Aug	*	B	M	*	B	T
11-12 Sep	NS			*	B	M
28-29 Sep	‡	T	B	NS		
1974						
21-22 Jun	—	—	—	*	B	M
12-13 Jul	*	B	T	*	M	T
23-24 Jul	*	B	T	*	B	T

* $P < 0.001$.

† $P < 0.01$.

‡ $P < 0.05$.

analyses of nighttime drift for the *Pseudocloeon-Baetis* group were significantly different from that expected, the top net showing the greatest overabundance of organisms eight times and the middle net four times. The bottom net was the most overabundant only once, and the most overabundant 11 times. The density of nighttime drift in the top net averaged more than twice the density in the bottom net. Twelve of fifteen analyses of daytime drift were significantly different from expectation, the top net showing the greatest overabundance four times, the middle net five times, and the bottom net three times.

Table 2. As Table 1, but for *Hydropsyche-Cheumatopsyche* group.

Period	Site 1			Site 2		
	Test result	Under	Over	Test result	Under	Over
Daytime drift						
1973						
27-28 Jul	*	T	M	*	T	B
13-14 Aug	†	T	Ml	NS		
28-29 Aug	‡	T	B	*	T	B
11-12 Sep	*	M	B	*	T	B
28-29 Sep	*	To	Bo	‡	To	Bo
9-10 Nov	*	T	M	*	T	B
30 Nov-1 Dec	NS			NS		
1974						
26-27 Feb	—	—	—	*	To	Bo
14-15 Mar	—	—	—	NS		
31 May-1 Jun	*	T	B	*	T	M
21-22 Jun	—	—	—	‡	B	M
12-13 Jul	*	T	B	*	T	M
23-24 Jul	*	T	M	*	T	B
Nighttime drift						
1973						
27-28 Jul	*	T	B	NS		
13-14 Aug	*	T	Ml	*	Mu	Ml
28-29 Aug	*	T	M	*	T	B
11-12 Sep	*	T	B	*	T	M
28-29 Sep	*	T	B	NS		
9-10 Nov	NS			*	T	B
30 Nov-1 Dec	†	M	B	NS		
1974						
26-27 Feb	—	—	—	*	T	B
14-15 Mar	—	—	—	*	T	M
31 May-1 Jun	*	B	M	*	T	B
21-22 Jun	—	—	—	‡	M	B
12-13 Jul	‡	T	M	*	T	B
23-24 Jul	*	T	B	*	T	B

* $P < 0.001$.

† $P < 0.05$.

‡ $P < 0.01$.

Nineteen of twenty-three vertical distribution analyses of nighttime drift for the *Hydropsyche-Cheumatopsyche* group were significantly different from that expected, the bottom net showing the greatest overabundance of organisms 12 times and the middle net seven times. The top net was never the most overabundant but showed the greatest underabundance 15 times. The density of nighttime drift in the bottom net averaged about twice that of the top net.

Nineteen of twenty-three analyses of daytime drift were significantly different

from expectation, the bottom net showing the greatest overabundance of organisms 12 times and the middle net seven times. The top net was never the most overabundant but was the most underabundant 17 times.

Drift density was seldom equal throughout the water column for the taxa examined. *Pseudocloeon* and *Baetis* generally exhibited overaccumulation in the upper nets during the night, with no consistent pattern during the day. The *Hydropsyche-Cheumatopsyche* group was strongly over-represented in the lower nets during both day and night.

Larimore (1972) noted periodic concentrations of drift organisms near the surface during the hours of maximum drift under low flow conditions. Ulfstrand (1968) found an over-representation of exuvia drifting along the bottom and felt that the distribution of exuvia might be seen as a drift model for small passive objects with a specific gravity near 1. Under this hypothesis an even distribution of organisms might indicate some activity by the organisms, influencing their position in the water column. One might expect strong swimming organisms (e.g. *Pseudocloeon* or *Baetis*), which may be able to seek a specific position in the water column, to show a nonrandom vertical distribution. On the other hand, those organisms having little ability to influence their orientation (e.g. *Hydropsyche* or *Cheumatopsyche*) should be over-represented in the lower strata. Differences in the ability of organisms to move within the water column may account for the skewed distributions of organisms that we observed. If upward movement is characteristic of an organism's nighttime behavioral drift pattern, this same behavior might not be observed during the day when entry into the drift may be largely inadvertent. This may explain, in part, the lack of a consis-

tent pattern of accumulation of *Pseudocloeon* and *Baetis* at a particular stratum during the day. The trichopterans, having little ability to influence their position whether in the light or the dark, showed a consistent distribution over the 24-h period.

There may be an even vertical distribution of drift density in small, turbulent streams (Waters 1965), but not in larger, less turbulent waters. Sampling procedures and analyses must be modified to detect and sample nonrandom distributions. Drift sampling in large rivers will remain a difficult task. Our apparatus proved to be efficient and of moderate cost but remains limited to depths of about 1.5 m.

William J. Matter²
A. J. Hopwood

Department of Biological Sciences
St. Cloud State University
St. Cloud, Minnesota 56301

References

- ELLIOTT, J. M. 1967. Invertebrate drift in a Dartmoor stream. *Arch. Hydrobiol.* **63**: 202-237.
- LARIMORE, R. W. 1972. Daily and seasonal drift of organisms in a warmwater stream. *Ill. Nat. Hist. Surv. Res. Rep.* 55, Univ. Ill., Urbana-Champaign. 105 p.
- PEARSON, W. D., AND R. H. KRAMER. 1969. A drift sampler driven by a waterwheel. *Limnol. Oceanogr.* **14**: 462-465.
- ULFSTRAND, S. 1968. Benthic animal communities in Lapland streams. *Oikos Suppl.* 10. 120 p.
- WATERS, T. F. 1962. A method to estimate the production rate of a stream bottom invertebrate. *Trans. Am. Fish. Soc.* **91**: 243-250.
- . 1965. Interpretation of invertebrate drift in streams. *Ecology* **46**: 327-334.
- . 1972. The drift of stream insects. *Annu. Rev. Entomol.* **17**: 253-272.

Submitted: 26 September 1977

Accepted: 27 May 1980

² Present address: School of Renewable Natural Resources, University of Arizona, Tucson 85721.