

## Feeding behavior of *Rhithrogena pellucida* (Ephemeroptera:Heptageniidae)

D. McSHAFFREY AND W. P. McCAFFERTY

*Department of Entomology, Purdue University, West Lafayette, Indiana 47907 USA*

**Abstract.** Larvae of *Rhithrogena pellucida* (Ephemeroptera:Heptageniidae) were observed feeding in observation flow cells using macroscopic video techniques. The stereotypic feeding behavior is described as cycles delineated by specific movements of the labial palps and consisting of stages of coordinated movement of the entire suite of mandibulate mouthparts. When employing the Labial Brushing Cycle, larvae used the labial palps to brush loosely accreted material from the substrate. When employing the Maxillary Scraping Cycle, larvae used special pectinate setae of the maxillary palps to remove material more tightly bound to the substrate. In both cycles, the legs of the larvae also removed material from the substrate. Larvae did not perform gathering cycles or feed on deposits of detritus. Food processing by successive fields of setae on various mouthparts to the point of ingestion is described in detail. Feeding observations combined with field and laboratory data on gut content and microhabitat distribution suggest that *R. pellucida* feeds primarily on periphyton. Comparisons are drawn between the primary scraping function of *R. pellucida* and the primary brushing function of *Stenacron interpunctatum*. A spectrum of adaptational strategies for obtaining food materials along a gradient of substrate association from seston to the most tightly attached materials is suggested and may be used to describe the feeding roles of many macroinvertebrates.

**Key words:** Ephemeroptera, Heptageniidae, *Rhithrogena pellucida*, *Stenacron interpunctatum*, feeding behavior, morphology, functional feeding groups, ecology.

The feeding behavior and functional morphology of the heptageniid mayfly *Stenacron interpunctatum*, and new methods for studying them, were reported by McShaffrey and McCafferty (1986). To allow these data to be viewed within a larger comparative context we subsequently studied another midwestern mayfly, *Rhithrogena pellucida*. This mayfly provides an interesting comparison because it too is a stream-dwelling member of the family Heptageniidae but lives in different habitats and possesses somewhat different mouthpart morphology. As with *S. interpunctatum*, our objectives with *R. pellucida* were to document both the feeding behavior and feeding structures. We did not attempt to document the entire range of behavior of the species, or to determine the nutritional significance of the material ingested.

Our functional morphology/behavioral approach to studying feeding incorporates field observations, gut content analysis, scanning electron microscopy (SEM), and videomacroscopy into a comprehensive research protocol. This allows critical examination of questions concerning diet and microhabitat and the related adaptations of feeding behavior and mouthpart morphology. An important feature of this system is its redundancy; all questions are investigated using multiple techniques. Be-

sides the comparative data that may have relevance to the study of adaptation and evolution, there are also obvious ecological applications. One that we have pursued involves the common practice of assigning functional feeding groups (FFG) (Cummins 1973) to the various members of aquatic communities.

Strenger (1953) studied the functional morphology of European species of *Rhithrogena* and included observations of behavior and interpretation of morphology. Strenger's work, although important, was limited by her inability to film behavior for detailed analysis and the fact that mouthpart morphology was not studied at the ultrastructural level. We are fortunate to have been able to extend such research by having SEM and videomacroscopic techniques available to us. *Rhithrogena* mayflies have previously been regarded as both collector-gatherers and scrapers (Cummins et al. 1984), with the primary designation being collectors.

### Methods

Organisms were collected in April 1986 from cobble substrate in the Tippecanoe River in north-central Indiana. They were maintained in the laboratory at room temperature (20-25°C) in 75 × 30 × 30-cm aquaria filled with substrate

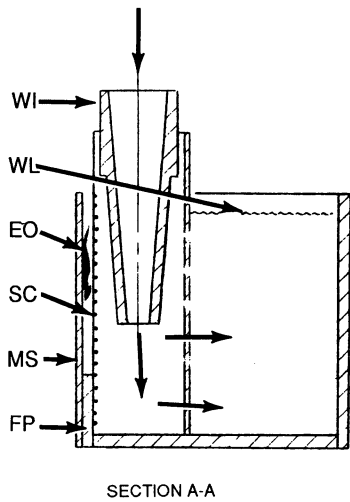
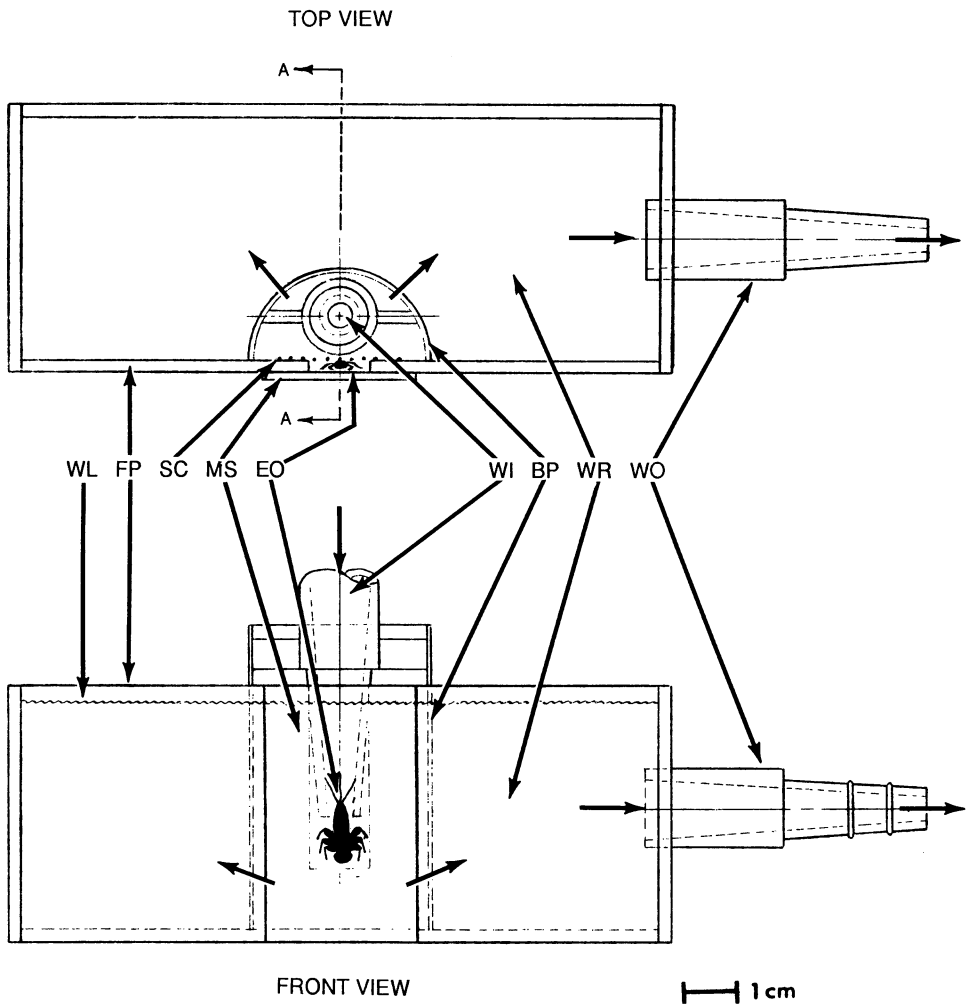

and water from the collection site; circulation was provided by airstones. Only mature larvae, as judged by relative wingpad development in Ephemeroptera larvae (McCafferty and Huff 1978), were used for observation and videotaping.

Observations were carried out using the techniques outlined in McShaffrey and McCafferty (1986), with some modifications. When studying *R. pellucida*, all observations were made using visible light supplied by a fiber optic illuminator to maximize resolution. Our experience showed that *S. interpunctatum* feeding movements were the same in visible and infrared light (McShaffrey and McCafferty 1986).

Most observations were made in an observation flow cell as described and illustrated in McShaffrey and McCafferty (1986). With *R. pellucida*, only the shallow (1 mm deep) flow cell was used. Water at room temperature (20–25°C) was fed into the cell by gravity from an aquarium mounted on the roof of the observational theater. Water leaving the cell collected in another aquarium; a pump controlled automatically by a depth-sensing switch periodically returned water to the upper tank. Water in both aquaria was aerated. The flow of water was regulated by a valve; current speed was adjusted as described in the study of *S. interpunctatum*, with the same inherent difficulties in determining precise current speed (McShaffrey and McCafferty 1986). In most cases the flow was increased until the individuals began to orient to the current, this usually occurred at low current velocities (1–5 cm/s).

In addition to the shallow flow cell, a tank cell was also employed. The tank cell (Fig. 1) was constructed of 2-mm-thick acrylic, 10.5 cm long, 4 cm wide, and 4 cm deep, and held a volume of 150 ml of water when in use. The front face had a 1 × 3-cm rectangular section removed from the center; a portion of a standard glass microscope slide was attached over the outside of this hole, and a 1-mm<sup>2</sup> mesh screen was attached over the inside to form an enclosure into which the individuals were placed.

This enclosure measured 1 cm long, 2 mm wide, with a water depth up to 3 cm. A hemicylinder of black plastic (radius 1.5 cm), with 30 2.5-mm-diameter holes, was placed around the enclosure on the inside of the tank. This plastic served to isolate the organism visually and reduce unwanted reflections during filming.

Water flow was provided as in the shallow flow cell; the water entered the tank cell through a tube attached with its outlet below the waterline inside the plastic hemicylinder directly behind the enclosure, and exited through another tube attached to one side of the tank cell. Water level in the cell was controlled by regulating inflow and outflow with valves. There was no noticeable water current in the enclosure. The tank cell was mounted in place of the shallow flow cell on the stage of the observational theater. The final position of the organism, vertical with the mouthparts facing the glass slide and the videocamera, was the same as in the flow cell.

Food for the experiments was provided as described in McShaffrey and McCafferty (1986). Diatoms and other periphyton collected in the Tippecanoe River were cultured on glass slides in the laboratory. The composition of the periphyton community on the slides was the same as the previous study—a 95% covering of the diatoms *Cocconeis* and *Achnanthes*, numerous bacteria between the diatoms, and the remaining 5% consisting of scattered fungal hyphae, *Oscillatoria*, *Cladophora*, *Melosira*, *Fragilaria*, *Chlorella*, rotifers, and protozoa. Scanning electron micrographs of typical growth on a slide surface are shown in Figure 2. Detritus taken from the holding tanks was introduced into the water flow in the shallow flow cell at both high (>5 cm/s) and low (<5 cm/s) flow rates; detritus was placed directly into the enclosure of the tank cell. Detritus settled to the bottom of the tank cell and the shallow flow cell at low flow rates; at high flow rates detritus moved through the shallow flow cell in suspension. We considered feeding effective if ingestion of the material was observed.

←

FIG. 1. Tank cell used in feeding experiments with *R. pellucida*, drawn to scale. Unlabelled arrows show direction of water flow. Abbreviations: BP = black plastic, EO = experimental organism, FP = front plate, MS = microscope slide (viewing port), SC = screen (1 mm<sup>2</sup>), WI = water inlet, WL = water line, WO = water outlet, WR = water reservoir.

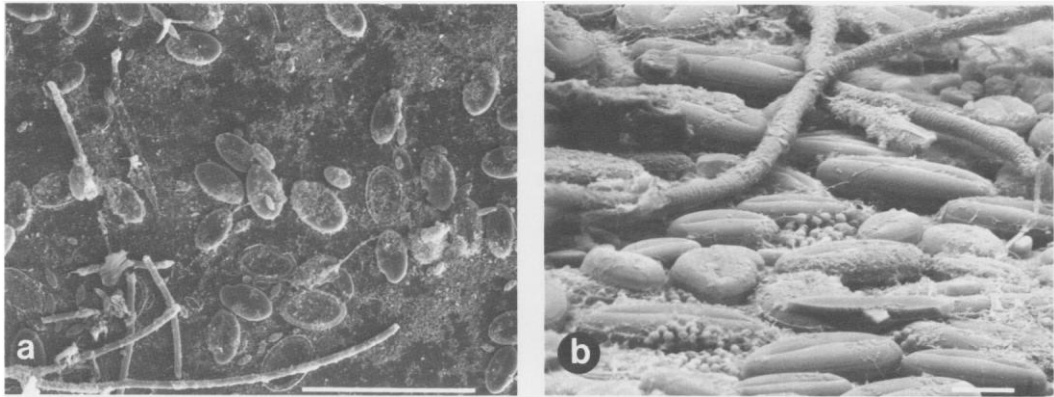

FIG. 2. SEM micrographs of the surface of a glass microscope slide used in feeding experiments. a. Plan view, bar = 100  $\mu\text{m}$ . b. Oblique view showing vertical distribution, bar = 10  $\mu\text{m}$ .

Motion analyses were carried out by examination of the videotape recordings of the observation sessions as in McShaffrey and McCafferty (1986). Owing to sparseness of specimens in the field, the need to sacrifice some individuals upon return to the laboratory for gut content analysis, and natural mortality, only 10 individuals were videotaped. Of the several hundred feeding cycles videotaped, 50 were analyzed in detail using single frame advance. The 50 feeding cycles chosen for detailed analysis were selected for visual clarity and presence of repeated feeding activity. Once a chronology of mouthpart movement was determined within these cycles, the chronology was tested against the remaining cycles. The feeding cycles are classified into stereotypic cycles as outlined in McShaffrey and McCafferty (1986) and adapted from the methods used by Trueman (1968) and Keltner and McCafferty (1986). Each stage is delineated by specific movements of the labial palps.

Mouthpart structures were examined using light microscopy and SEM. Specimens were prepared for SEM by dehydration in increasing concentrations of ethanol from 75% to 100%, then transferred to 100% ethyl acetate. Some specimens were sonicated in 100% ethyl acetate for one minute in an ultrasonic cleaner to remove food material from the mouthparts; others were not sonicated so that the position of material on the mouthparts might be determined. The larvae were then either dissected or transferred whole to the SEM stubs after air drying. This method produces very little dis-

tortion of mouthparts and is much faster than critical point drying.

Gut contents of living larvae were placed on glass microscope slides and examined immediately with a compound microscope. Gut contents were classified as being mineral, organic detritus, diatoms, filamentous algae, unicellular green algae, animal remains, or bacteria. No attempt was made to quantify proportions other than to determine what type predominated. Periphyton species present in the field were determined by returning substrate to the laboratory, carefully removing the periphyton, and examining it under a compound microscope.

## Results

### Field observations

Our knowledge of the life cycle of *R. pellucida* in the Tippecanoe River is based on extensive collections from the same site from 1983 to 1987. Diligent searching of all microhabitats during weekly intervals from April 1985 to July 1986 produced *R. pellucida* samples only during April and May. Most of these larvae were relatively mature and were always collected off the upper surfaces of stones or collected in kick screen samples. The larvae were also always found in mid-stream where the substrate receives direct sunlight and the periphyton community is well developed.

When *R. pellucida* larvae were found, the cobble substrate was covered by a diverse aufwuchs community, including diatoms such as *Gom-*

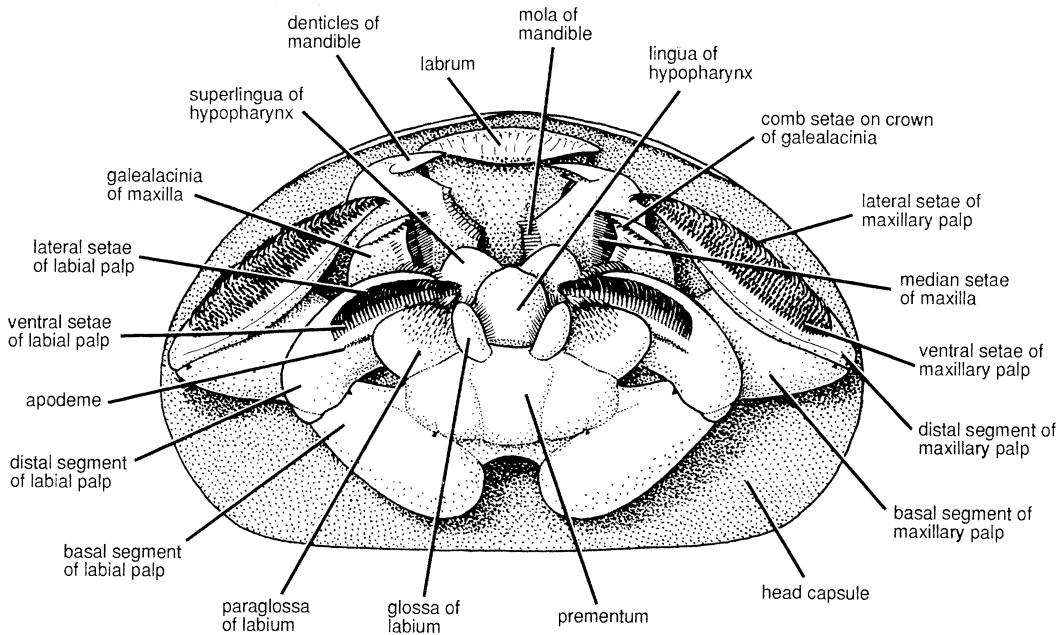

FIG. 3. Ventral view of mouthparts of *Rhithrogena pellucida*, mouthparts have been positioned to allow underlying structures to be seen.

*phonema*, *Navicula*, *Fragilaria*, *Melosira*, *Cocconeis*, *Achnanthes*, and *Synedra*. *Cladophora*, which was also present throughout the period when *R. pellucida* larvae were found, reached a growth peak in early May at the same time *R. pellucida* adults emerged. It appears that *R. pellucida* in the Tippecanoe River is univoltine, with emergence and egg-laying in early May. Although we do not have data on the egg stage or the early instars, it is probable that the eggs hatch in winter, with mature larvae appearing on the upper surfaces of rocks in April.

#### Effects of experimental conditions on behavior

*Rhithrogena pellucida* larvae were highly stereotypic in their mouthpart movements. External factors such as noise, vibration or change in light intensity often appeared to initiate feeding movements; however, these movements were qualitatively similar to those observed under other conditions. Feeding cycles induced by external stimuli usually ceased after 1-2 cycles, whereas non-induced feeding cycles were usually repeated at least 5 times. Specimens in the holding aquaria were positively rheotactic. During the course of this study, lar-

vae never attempted to feed on detritus or to filter feed.

#### Stereotypic feeding behavior

**Resting position:** When a larva is not feeding, the mouthparts (Figs. 3-5) are held in a characteristic resting position (Fig. 6a). The distal segments of the labial palps are held folded inward so that they lie over (dorsal to) the paraglossae but not the glossae. The labium as a whole is held adducted dorsally to close the

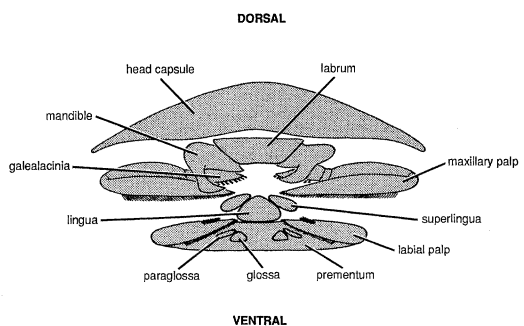

FIG. 4. Diagrammatic cross-section of the mouthparts of *Rhithrogena pellucida*, showing relative ventral positions.

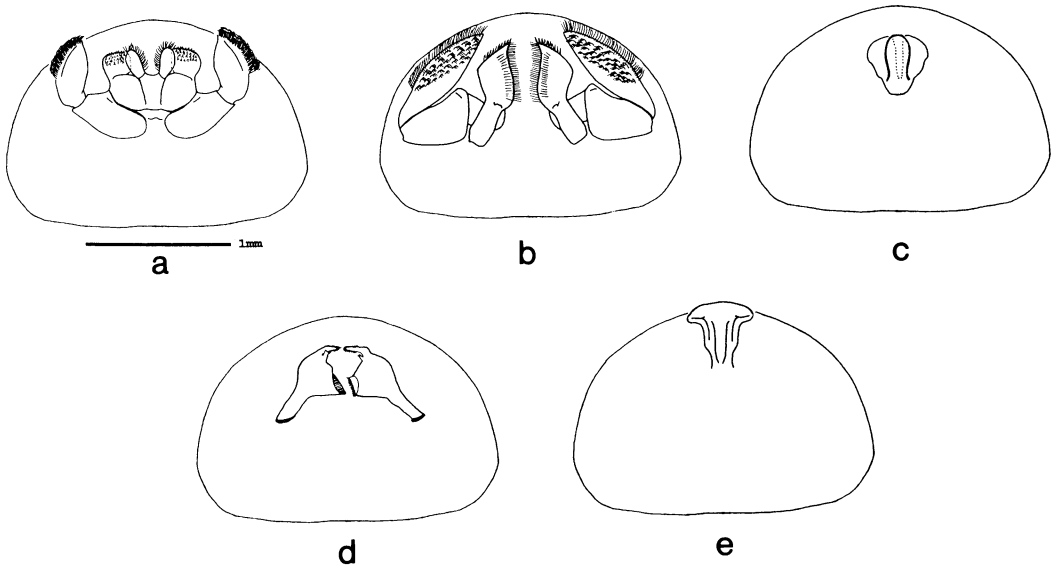

FIG. 5. Ventral view of *Rhithrogena pellucida* mouthparts, ventral to dorsal sequence. a. Labium. b. Maxillae. c. Hypopharynx. d. Mandibles. e. Labrum. Scale (as shown in a) is constant for all figures.

preoral cavity ventrally. The galealaciniae of the maxillae are positioned with their median setae touching the lingua of the hypopharynx; the galealaciniae also are in contact ventrally with the labial palps and dorsally with both the superlinguae of the hypopharynx and the mandibles. The maxillary palps are held with the basal segments perpendicular to the long axis of the body; the distal segments are folded forward at a 45° angle to the basal segments. The basal segments of the maxillary palps do not extend beyond the contour of the head capsule; the distal segments of the maxillary palps parallel the contour, extending just slightly beyond it. The apices of the distal segments of the maxillary palps do not meet but extend only to the lateral edges of the labrum. The labrum and the maxillary palps together cover the anterior and lateral aspects of the preoral cavity. The labrum is in contact with the denticles of the mandibles ventrally. The denticles of the mandibles are held separated, and presumably the molae are closed.

**Feeding cycles:** Larvae placed in the observation cell with diatoms grown on the glass slide performed two different behavioral cycles; we term these brushing and scraping cycles. The two cycles differ in the degree to which the maxillary palps are employed. In the Labial Brushing Cycle, the labial palps are used as

brushing tools; in the Maxillary Scraping Cycle, the maxillary palps are used as scraping tools. Each cycle consists of several stages that can be delineated by specific movements of the labium. A single cycle of either type takes 1.2 s at 20°C. Mouthpart movements described below are often preceded by and concurrent with movement of the forelegs ahead (upstream) of the individual. Legs are alternately and repeatedly extended and then retracted, drawing the claws over the substrate. These leg movements were capable of removing tightly adhering material from the substrate and bringing it to the mouthparts.

**Labial Brushing Cycle: Stage 1.**—Abduction of the basal segments of the labial palps: As feeding commences, the labium begins to swing ventrally towards the substrate. The basal segments of the labial palps swing posteriorly about 20° (Fig. 6b); this movement draws the distal segments of the labial palps away from contact with the paraglossae. Once the apices of the labial palps clear the paraglossae, the labium completes its ventral movement and comes to rest against the substrate. At this point the basal segments of the maxillary palps swing posteriorly about 20°. The galealaciniae do not move in Stage 1 of the initial brushing cycle in the series, but in all subsequent cycles of the series they move medially at this point in Stage 1. The

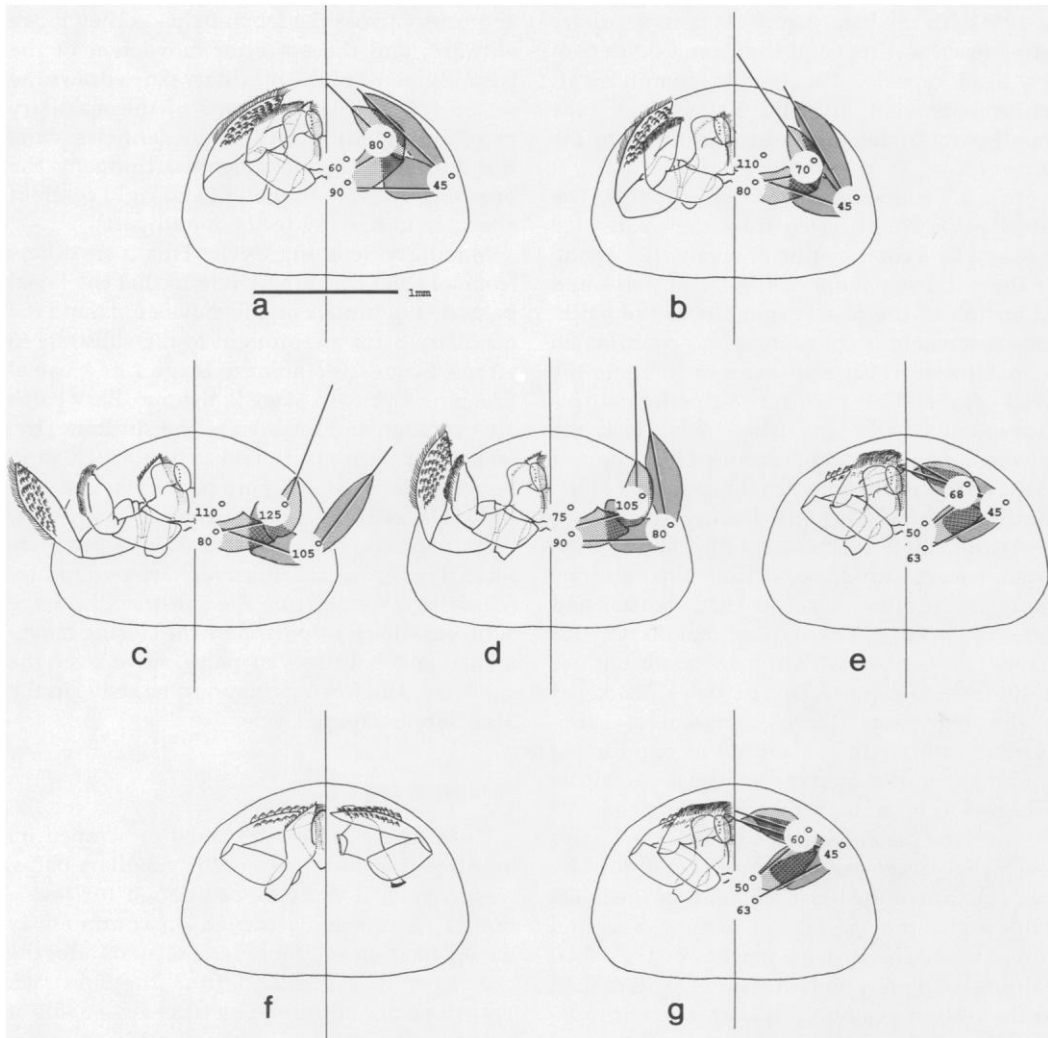

FIG. 6. Relative positions (all in ventral view) of *Rhithrogena pellucida* mouthparts during various stages of a Labial Brushing Cycle. a. Resting Position: Labium and Maxilla, left; Labial and Maxillary Palps, right. b. Stage 1 of first cycle: Labium and Maxilla, left; Labial and Maxillary Palps, right. c. Stage 2 of first cycle: Labium and Maxilla, left; Labial and Maxillary Palps, right. d. Intermediate position of Stage 3 of first cycle: Labium and Maxilla, left; Labial and Maxillary Palps, right. e. Final position of Stage 3 of first cycle: Labium and Maxilla, left; Labial and Maxillary Palps, right. f. Final position of Stage 3 of first cycle: Maxilla and Hypopharynx, left; Maxilla and Mandible, right. g. Stage 1 of second and all subsequent cycles: Labium and Maxilla, left; Labial and Maxillary Palps, right.

labrum begins to move down slightly to shield the front of the other mouthparts.

*Stage 2.*—Abduction of the distal segments of the labial palps: Once the basal segments of the labial palps reach their posterior position, the distal segments of the labial palps are abducted, moving through a range of about  $50^\circ$  until they are at an angle of  $125^\circ$  to the basal segments

(Fig. 6c). When the labial palps are fully extended they extend just beyond the contour of the head capsule. At this point the galealacinae complete their medial movement and are now abducted, moving laterally outward. The distal segments of the maxillary palps are extended at the same time as the labial palps, moving through an angle of about  $60^\circ$  to make an angle

of 105° with the basal segments. The maxillary palps reach well beyond the lateral borders of the head capsule. The labrum completes its movements ventrally and helps shield the mouthparts under the head capsule from the current.

*Stage 3.*—Retraction of the labial palps: The labial palps are retracted from their extended position by a combination of an anterior swing of the basal segments of the labial palps and adduction of the distal segments of the palps. This movement is continuous and coordinated so that the labial palps always remain under the head capsule. The maxillary palps follow this movement closely; the labial palps lead the movement and remain positioned just anterior to the articulations between the segments of the maxillary palps (Fig. 6d). During this movement the distal segments of the labial palps brush (sweep) up material from the substrate using the profuse setae on their ventral and anterior surfaces. The trailing maxillary palps are not in contact with the substrate but are positioned to capture any particles dislodged by the labial palps. If foreleg movement is concurrent with feeding, the claw of one foreleg is brought to the corresponding labial palp as it begins to be adducted during this stage.

When the distal segments of the labial palps reach the paraglossae they are raised dorsally by a rotation of the basal segments of the labial palps so that they pass dorsal to the glossae and paraglossae. The distal segments of the labial palps reach a position that is more median than in the resting position (Fig. 6e). The entire labium is raised as soon as the distal segments of the labial palps are dorsal to the glossae and paraglossae. The galealacinae follow the labial palps in moving medially; they also move somewhat ventrally. The denticles of the mandibles complete their lateral outward movement and the distal segments of the maxillary palps rotate and are inserted among these denticles (Fig. 6f). The labrum moves dorsally.

As feeding continues, this brushing cycle is repeated in a series of these cycles. Subsequent cycles in the series are initiated by a slightly further adduction of the distal segments of the labial palps (Fig. 6g), followed by the abduction of the basal segments of the labial palps as in Stage 1. The brushing cycle is repeated unchanged except that in Stage 1 of subsequent cycles the galealacinae are moving medially

and brush across the labial palps as they move outward, and the posterior movement of the basal segments of the maxillary palps draws the setae on the distal segments of the maxillary palps through the combs on the denticles of the mandibles. If leg movements accompany the brushing cycle, then the left and right forelegs alternate in moving to the mouthparts.

**Maxillary Scraping Cycle:** This cycle differs from a Labial Brushing Cycle in that the labial palps do not initiate all the movements, and the maxillary palps are brought to the substrate to scrape. Stage 1 is similar to Stage 1 of a Labial Brushing Cycle. In Stage 2, the maxillary palps are extended and lowered to the substrate; the labial palps are positioned in the articulation between the maxillary palp segments. The ventral surfaces of the distal segments of the maxillary palps are covered with unique pectinate setae (Fig. 7) which effectively remove tightly adhering material from the substrate. In Stage 3, the maxillary palps initiate the closing movements, and both sets of palps move over the substrate. The forelegs may also be active in the Maxillary Scraping Cycle.

#### *Food processing*

Once food has been brushed or scraped up by either the labial palps or the maxillary palps, respectively, it must be positioned for ingestion. This process is carried on continuously during feeding and for several seconds after the last material is procured from the substrate. Transfer is accomplished by successive fields of setae on the various mouthparts (Fig. 3) as described below. Food transport is similar for both the Labial and Maxillary Feeding Cycles.

After completion of the first cycle, and when the labial palps are extended again (Stage 1), material on the setae of the distal segments of the labial palps is removed in two ways. Outward lateral movement (Stage 1) of the distal segments of the labial palps causes material to be combed from the ventral setae of the labial palps by setae on the dorsal surfaces of the glossae and paraglossae. Most of the material on the distal segments of the labial palps is carried by the lateral and dorsal setae. This material is removed by the comb setae on the crown of the galealacinae as the distal segments of the labial palps are adducted further and then moved laterally outward by the posterior movement of

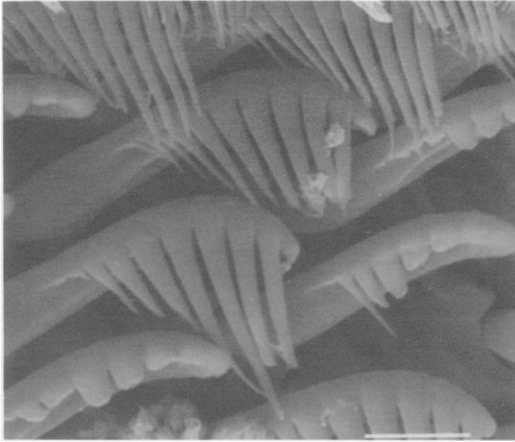

FIG. 7. SEM micrograph of the setae on the ventral surface of the maxillary palps of *Rhithrogena pellucida*, bar = 10  $\mu$ m.



FIG. 8. SEM micrograph of the mandibular molae and epipharynx of *Rhithrogena pellucida*. The molae are at the bottom of the micrograph, the epipharynx is at the top. The pharynx can be seen just above the diatoms, which have passed through the molae. Bar = 10  $\mu$ m.

the basal segments of the labial palps (Stage 1). The comb setae of the galealacinae are brought into contact with the distal segments of the labial palps by the slight adduction of the distal segments of the labial palps at the beginning of the outward movement and with a ventral movement of the galealacinae. Material in the comb setae is removed by stout setae on the dorsal sides of the distal segments of the labial palps when the comb setae are drawn base-first through them as the distal segments of the labial palps are adducted medially (Stage 3). Material on the comb setae may also be removed when the galealacinae move laterally outward (Stage 2); this draws the comb setae base-first through the setae on the dorsal sides of the glossae and paraglossae. In both types of cycles, any material on the maxillary palps is removed by combs on the mandibular denticles as the palps are withdrawn (Stage 2).

Material left on the glossae and paraglossae and on the dorsal surfaces of the distal segments of the labial palps is moved further through a number of processes. As the labial palps return to the preoral cavity (Stage 3), this material is displaced posteriorly, medially, and dorsally by the labial palps and the new load of material they bear. As the galealacinae move medially (Stage 1 and Stage 2), their median setae push the material between the superlinguae and the lingua of the hypopharynx (Fig. 6f). The lingua bears dorsal rows of setae which guide the ma-

terial to a point where it can be pressed against the mandibular molae for straining and ingestion (Fig. 8). Presumably, material left on the denticles of the mandibles is brushed directly onto the dorsum of the hypopharynx or the venter of the epipharynx by the movements of the mandibles; we have not been able to observe this directly since this area is obscured by the other mouthparts.

In both types of cycles the maxillary palps are used to displace larger particles from the preoral cavity and to brush material from the comb setae on the galealacinae. Once food acquisition ceases, the mouthparts remain in motion as described above for several cycles, moving material into position to be ingested. During this phase, the labial palps make only small movements, primarily slight adductions of the distal segments, and the maxillary palps only brush against the mandibular denticles and the galealacinae (they do not sweep the substrate).

#### *Gut content analysis*

Gut contents of four larvae collected in the field were analyzed along with those of one larva that had been videotaped. All five guts were similar in content; they contained diatoms, organic detritus and sediment. The predominant material was intact diatom frustules;

there was also considerable organic detritus apparently of algal origin. Diatoms found in the gut included: *Navicula*, *Gomphonema*, *Melosira*, *Cocconeis*, *Achnanthes*, *Fragilaria*, and *Rhoicosphenia curvata*; *Navicula* species were the most common. None of the guts contained intact filamentous algae or recognizable animal remains.

### Discussion

Our observational procedures required the organisms to be confined inside a small cell made of synthetic materials, and it exposed them to unnatural light and water flow regimes. In our study of *S. interpunctatum* (McShaffrey and McCafferty 1986), we found that our experimental conditions did affect the overall behavior of that species, but did not affect the actual feeding movements reported. With *S. interpunctatum*, we were able to study individuals not confined to an observation cell, and we made observations using infrared light to simulate the low-light nature of the crevices in which we collected the larvae in the field (McShaffrey and McCafferty 1986). We were not able to collect enough *R. pellucida* larvae to permit observations outside the observation cell, but our experience with *S. interpunctatum*, *Ephemerella needhami*, and various other Ephemeroptera, Trichoptera, Diptera, Odonata, Coleoptera, Amphipoda, and other freshwater macroinvertebrates (unpublished data) suggests that the cyclic movements of the mouthparts are stereotypic and vary little between conspecifics of the same age class. This conclusion is consistent with data from other insect feeding studies (Brown 1960, Chance 1970, Devitt and Smith 1985, Froehlich 1964, Pucat 1965).

Our observations are similar to those made by Strenger (1953) for a European species of *Rhithrogena*. We were not able to confirm her suggestion that the distal segments of the labial palps deform their surfaces; this reportedly would enable their setal patches to open and close and thus increase feeding efficiency (Strenger 1953). We also were not able to document the function of the brush on the mola of the right mandible; Strenger (1953) stated that it is used to carry food from the hypopharynx to the left mola. In both cases, it is possible that Strenger (1953) did not actually

observe these movements but inferred them based on her extensive morphological studies. We were able to observe some opening and closing of the setae of the distal segments of the labial palps, but we cannot eliminate the possibility that such movements are passive responses to drag as the palps are moved against the substrate, the water, or the other mouthparts. The molar region of the mandibles is completely obscured by the other mouthparts, and we were not able to observe this area directly. We had to estimate molar action based on the movement of the denticles, which were visible.

Because *R. pellucida* and *S. interpunctatum* are both flatheaded mayflies of the subfamily Heptageniinae, and can be found coexisting in the same general area of streams, it is interesting to compare their morphology, microhabitat, and feeding movements. *Stenacron interpunctatum* is found in slow-current areas, on the bottom of stones, away from the current (Flowers and Hilsenhoff 1978, McShaffrey and McCafferty 1986, Wiley and Kohler 1980, Wodsedalek 1912). We observed *R. pellucida* living on the tops of stones in high-current areas; Flowers and Hilsenhoff (1978) also found this species in high-current microhabitats. Strenger (1953) reported that the European species she studied were also collected on the tops of stones. The difference in microhabitat is further reflected in the gut contents of these species. Whereas *S. interpunctatum* is primarily a detritivore (Lamp and Britt 1981, McShaffrey and McCafferty 1986), the *R. pellucida* studied here are primarily periphyton feeders.

The short developmental period for *R. pellucida* in the spring (see also Clifford 1982, Flowers and Hilsenhoff 1978) is associated with its feeding habits. *Rhithrogena pellucida* in the Tippecanoe River is only found in early spring before *Cladophora* growth is significant, whereas *S. interpunctatum* occurs year-round at the same site. In this river, a narrow temporal window in which there is good periphyton development on the rock substrate occurs during the latter part of April to early May. The end of this period is marked by *Cladophora* overgrowth of the substrate; presumably the filaments of the *Cladophora* interfere with the feeding of *R. pellucida*, which requires a relatively flat substrate free of obstructions to the movements of the maxillary palps. *Stenacron interpunctatum* feeds on detritus, which is always available, and has

a complex life history with larvae present year-round (McCafferty and Huff 1978).

Morphological differences between the mouthparts of *R. pellucida* and those of *S. interpunctatum* correspond to the different microhabitats. In *R. pellucida* they are apparently adaptations allowing the removal of tightly-bound material on the upper surfaces of rocks. The primary difference is the increased development of the maxillary palps of *R. pellucida* (compare Fig. 5b with figs. 2 and 4b in McShaffrey and McCafferty [1986]). Corresponding to increased development of the maxillary palps is a flattening and broadening of the mandibular denticles (compare Fig. 5d with figs. 2, 3, and 4d in McShaffrey and McCafferty [1986]) to accommodate the larger maxillary palps involved in removal of food particles. Other secondary morphological differences between *R. pellucida* and *S. interpunctatum* reflect a decrease in importance of the labial palps to *R. pellucida* as food-gathering organs. *Rhithrogena pellucida* has fewer comb setae on the galealaciniae; and the hypopharynx, which is important in transferring material from the labium to the molae, is greatly reduced (compare Fig. 5c with fig. 4c in McShaffrey and McCafferty [1986]). Strenger (1953) noted similar differences when comparing *Rhithrogena* and *Ecdyonurus* in Europe.

The brushing cycle of *S. interpunctatum* is very similar to the Labial Brushing Cycle of *R. pellucida*, the major difference being an improved coordination of the movements of the maxillary and labial palps in *R. pellucida*. This improved coordination places the maxillary palps in a position closely following the labial palps to capture any material swept up by the labial palps but not captured by them. Such improved efficiency may be vital in a higher-current microenvironment. The Maxillary Scraping Cycle of *R. pellucida* is much more effective than either the Labial Brushing Cycle of *R. pellucida* or Brushing Cycle of *S. interpunctatum* in removing tightly adhering material from the substrate owing to the use of the large maxillary palps with their unique setae.

We did not observe *R. pellucida* performing cycles similar to the filtering or gathering cycles we found in *S. interpunctatum* (McShaffrey and McCafferty 1986). Although none of the *R. pellucida* in this study would feed on deposits of detritus, such feeding probably would be effective when the Labial Brushing Cycle is em-

ployed. Similarly, although none of the *R. pellucida* were observed filter-feeding, the large, well-muscled maxillary palps, with their fringe of bipectinate setae (similar to those present on the small maxillary palps of *S. interpunctatum*) appear adequate for filtering. At this time we cannot discount the possibility of *R. pellucida* filter-feeding or deposit-feeding (gathering). We had been unable to confirm a scraping function for the forelegs of *S. interpunctatum* (McShaffrey and McCafferty 1986); however, we were able to document such a capability for *R. pellucida* in the present study.

With regard to FFG classification, *R. pellucida* is best defined as a scraper based on the ability of the maxillary palps and legs to remove tightly adhering material from the substrate, and the presence of significant amounts of periphyton in the gut contents. It also, however, brushes, particularly when using the Labial Brushing Cycle.

The ability of an organism to use more than one mode of feeding—whether it be *R. pellucida* scraping and brushing, *S. interpunctatum* using the same mouthparts to brush, collect-gather, and filter, or different developmental stages of a single species using different feeding methods (Cummins 1973, Cummins and Merritt 1984)—complicates the problem of pigeonholing species into FFGs. This complexity is aggravated by attempting to assign FFGs based on gut contents that are often unidentifiable. Our study of *R. pellucida* and other aquatic insects suggests that a more mechanical approach to delineating FFGs for benthic insects that feed on relatively small materials (microvores, sensu McCafferty 1981) may be appropriate. In this scheme, potential food material, regardless of origin, is viewed in terms of a continuum ranging from material suspended in the water, to material settled on the substrate, to material bound or growing attached to the substrate. Various feeding strategies are adapted to deal with various sections of this continuum.

In our scheme, benthic microvores can be divided into two basic groups, **Filterers** and **Collectors**. Filterers derive food material from the water, and the filter may consist of either parts of the body or manufactured devices such as silk nets. Passive filterers rely on seston already moving to their filtering apparatus, whereas active filterers generally resuspend deposits to filter. Thus, depending on the immediate source

of the food material, we classify benthic filterers as either *seston filterers* or *deposit filterers*. Collectors remove deposits or attached material from a substrate by direct contact of the feeding structures with the food material. Collectors can be divided into three groups: *brushers*, *gatherers*, and *scrapers*. Brushers use setae to obtain loose or lightly attached material and are often morphologically, functionally, and behaviorally close to deposit filterers. Gatherers feed on similar materials but primarily use structures other than setae for food-gathering. Scrapers have adaptations that allow them to feed on tightly accreted material.

To summarize, benthic filterers and collectors exhibit a range of feeding strategies for feeding on a spectrum of small particles ranging from suspended materials (seston filterers) to deposits of various integrity (deposit filterers, brushers, gatherers) to firmly attached materials (scrapers). As is the case for *R. pellucida* and *S. interpunctatum*, species may not be limited to one strategy. This scheme is attractive because habitats can be characterized hydraulically, and the FFG composition of the microvore community can be estimated based on the physical state in which the hydraulic forces will place the food material. In this context, concepts of community development can be based on the relative amounts of microhabitat available to provide food material in different positions in the environment and with different propensities for attachment. One drawback of such a classification system is that it provides little information about the origin of the material (i.e., primary production, detritus, etc.); however, under natural conditions many benthic macroinvertebrate microvores feed on a variety of materials and only a relatively few species are dependent on a single trophic level for their food resources. As indicated above, the system excludes macrovores such as shredders, miners, engulfers, and many predators.

Erecting a new FFG classification system is perhaps premature; however, such a system may become necessary as the behavior of more species of aquatic insects is studied in detail. For instance, Dahl et al. (1988) recently presented a classification scheme of FFGs for the Culicidae that also further divided the FFGs of Cummins and Klug (1979) into more discrete groupings based on the mechanism of food acquisition. It is notable that Dahl et al. (1988)

chose to use the term brushers to describe a feeding system found in certain Culicidae. Those authors were evidently unaware of the brusher concept of McShaffrey and McCafferty (1986); from their discussion it is not clear whether their mosquito "brushers" feed by direct contact of the mouthparts with deposits (as is the case with *S. interpunctatum*), or if the mouthparts create a current which carries the material to the mouthparts (deposit filtering, herein), or both.

This study of *R. pellucida* shows the utility of our approach in investigating questions about the functional morphology of feeding and adaptations to differing environments. Comparisons between this research and our work on *S. interpunctatum* illustrate how these investigative techniques, when applied to coexisting species, increase understanding of problems related to resource partitioning.

#### Acknowledgements

Arwin Provonsha provided Figures 3 and 4; Annn Delleur provided Figure 1. Dan Bloodgood assisted with the construction of the observation flow cell. The scanning electron microscope was made available by the Electron Microscopy Center in Agriculture at Purdue University with support from NSF grant PCM-8400133.

Purdue University Agricultural Experiment Station Journal No. 11,359.

#### Literature Cited

- BROWN, D. S. 1960. The ingestion and digestion of algae by *Cloeon dipterum* L. (Ephemeroptera). *Hydrobiologia* 16:81-96.
- CHANCE, M. M. 1970. The functional morphology of the mouthparts of black fly larvae (Diptera: Simuliidae). *Quaestiones Entomologicae* 6:245-284.
- CLIFFORD, H. F. 1982. Life cycles of mayflies (Ephemeroptera), with special reference to voltinism. *Quaestiones Entomologicae* 18:15-90.
- CUMMINS, K. W. 1973. Trophic relations of aquatic insects. *Annual Review of Entomology* 18:183-206.
- CUMMINS, K. W., G. F. EDMUNDS, AND R. W. MERRITT. 1984. Summary of ecological and distributional data for Ephemeroptera (mayflies). Table 10A, pages 122-125 in R. W. Merritt and K. W. Cummins (editors). *An introduction to the aquatic in-*

- sects of North America. Kendall-Hunt Publishing Company, Dubuque, Iowa.
- CUMMINS, K. W., AND M. J. KLUG. 1979. Feeding ecology of stream invertebrates. *Annual Review of Ecology and Systematics* 10:147-172.
- CUMMINS, K. W., AND R. W. MERRITT. 1984. Ecology and distribution of aquatic insects. Pages 59-65 in R. W. Merritt and K. W. Cummins (editors). *An introduction to the aquatic insects of North America*. Kendall-Hunt Publishing Company, Dubuque, Iowa.
- DAHL, C., L. E. WIDAH, AND C. NILSSON. 1988. Functional analysis of the suspension feeding system in mosquitoes (Diptera:Culicidae). *Annals of the Entomological Society of America* 81:105-127.
- DEVITT, B. D., AND J. J. B. SMITH. 1985. Action of mouthparts during feeding in the dark-sided cutworm, *Euxoa messoria* (Lepidoptera:Noctuidae). *Canadian Entomologist* 117:343-349.
- FLOWERS, R. W., AND W. L. HILSENHOFF. 1978. Life cycles and habitats of Wisconsin Heptageniidae (Ephemeroptera). *Hydrobiologia* 60:159-171.
- FROELICH, C. G. 1964. The feeding apparatus of the nymph of *Arthroplea cogener* Bengtsson (Ephemeroptera). *Opuscula Entomologica* 29:188-208.
- KELTNER, J., AND W. P. MCCAFFERTY. 1986. Functional morphology of burrowing in the mayflies *Hexagenia limbata* and *Pentagenia vittigera*. *Zoological Journal of the Linnaean Society* 87:139-162.
- LAMP, W. O., AND N. W. BRITT. 1981. Resource partitioning by two species of stream mayflies (Ephemeroptera:Heptageniidae). *Great Lakes Entomologist* 14:151-157.
- MCCAFFERTY, W. P., AND B. L. HUFF. 1978. The life cycle of the mayfly *Stenacron interpunctatum* (Ephemeroptera:Heptageniidae). *Great Lakes Entomologist* 11:209-216.
- MCSHAFFREY, D., AND W. P. MCCAFFERTY. 1986. Feeding behavior of *Stenacron interpunctatum* (Ephemeroptera:Heptageniidae). *Journal of the North American Benthological Society* 5:200-210.
- PUCAT, A. M. 1965. The functional morphology of the mouthparts of some mosquito larvae. *Quaestiones Entomologicae* 1:41-86.
- STRENGER, A. 1953. Zur Kopfmorphologie der Ephemeridenlarven. I. Teil *Ecdyonurus* und *Rhithrogena*. *Österreichische Zoologische Zeitschrift* 4: 191-228.
- TRUEMAN, E. R. 1968. A comparative account of the burrowing process of species of *Maetra* and of other bivalves. *Proceedings of the Malacological Society of London* 38:139-151.
- WILEY, M. J., AND S. L. KOHLER. 1980. Positioning changes of mayfly nymphs due to behavioral regulation of oxygen consumption. *Canadian Journal of Zoology* 58:618-622.
- WODESDALEK, J. E. 1912. Natural history and general behavior of the Ephemeridae nymphs *Heptagenia interpunctata*. *Annals of the Entomological Society of America* 5:31-40.

Received: 6 November 1987

Accepted: 5 May 1988